





GT- EL 60

6.000 Kg

-  Sollevatore a 2 colonne senza base
-  Two post lift without baseframe
-  Zweisäulenhebebühne ohne Grundrahmen
-  Elévateur a deux colonnes sans base
-  Elevador a dos columnas sin base



DATI TECNICI	TECHNICAL DATA	TECHISCHE DATEN	DONNÉES TECHNIQUES			X	XL
Portata max.	Max. capacity	Max. Tragfähigkeit	Portée max.	kg	6000	6000	6000
Tempo di salita / discesa	Lifting / lowering time	Hubfahrt-/ Senkfahrdauer	Temps de montée / descente	s	50/50	50/50	50/50
Alimentazione	Power supply	Stromversorgung	Alimentation		230-400V 3ph 50-60Hz		
Potenza motore	Electric motor power	Motorleistung	Puissance du moteur	kW	2x3,6 (400V 3ph 50Hz)		
Altezza max.	Max height	Max Höhe	Hauteur maxi	mm	2620	3810	4510
Tensione circuito comandi	Circuit voltage command	Leerlaufspannung Befehl	Circuit de commande de tension	V	24		

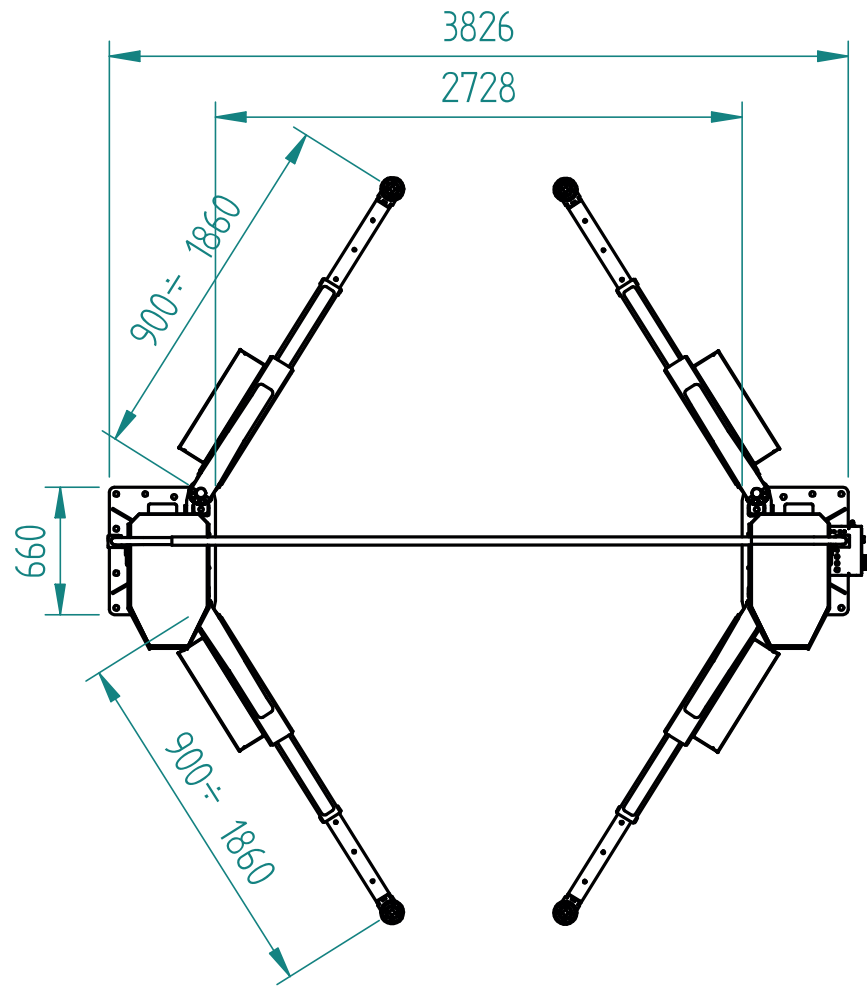
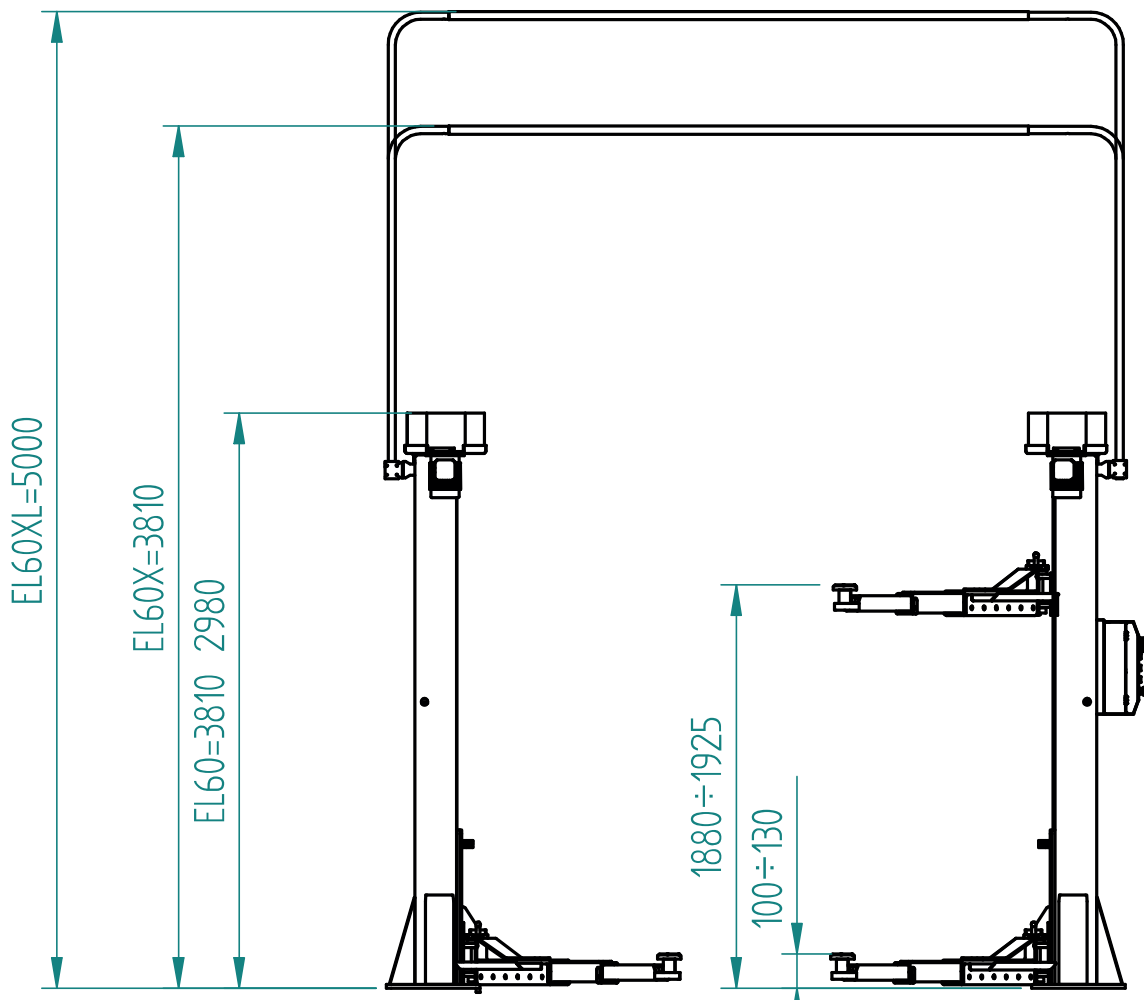



Motore speciale ad alto rendimento per garantire potenza e durata nel tempo, dotato di sonda termica di protezione

Specially manufactured motor fitted with overheating & overload protection switch
 Spezieller Hochleistungsmotor mit Thermoschutz liefert üppig bemessene Antriebsleistung und gewährleistet lange Lebensdauer

Moteur spécial à haute performance pour garantir puissance et durée dans le temps, équipé de sonde thermique de protection

Motor especial de alto rendimiento para garantizar potencia y duración en el tiempo, suministrado con termico de protección

Vite rullata in acciaio ad alta resistenza

Steel high resistance rolled screw to provide long life

Kaltgewaltze Spindel aus gehärtetem Stahl für eine lange Lebensdauer

Vis en acier, roulée, à haute résistance, pour garantir la durée dans le temps

Husillo de acero de alta resistencia, rosca fabricada en frio con rodillos para garantizar la maxima duración en el tiempo



Chiocciola portante in PA 6 + MoS2 ad elevata resistenza e sicurezza totale

PA 6 + MoS2 main nut with high resistance to wear for greater safety

Verschleissfeste Tragmutter aus PA 6 + MoS2 gewährleistet totale Sicherheit

Ecrou porteur en PA 6 + MoS2 à haute résistance à l'usure pour garantir une sécurité totale

Tuerca principal en PA 6 + MoS2 de alta resistencia al desgaste para garantizar la seguridad total



- Sollevatore con sincronizzazione elettronica senza base con massima comodità di movimento della zona di lavoro.
- Possibilità di installazione cavi elettrici al soffitto o incassati nel pavimento.
- La sincronizzazione elettronica fra i carrelli mantiene il dislivello entro un massimo di 24 mm.
- Comandi in bassa tensione.
- Bracci corti e bracci lunghi a tre stadi per il sollevamento asimmetrico di furgoni e fuoristrada.
- Tamponi con altezza minima di soli 85 mm.



- Lift with electronic synchronisation without baseframe for easy movement in the working area.
- The connecting cables can be fixed to the ceiling or recessed into the floor
- Electronic synchronisation between carriages to keep the height difference within max 24 mm
- Low voltage controls
- Short and long three-stage arms for the asymmetric lifting of vans and 4-wheel drive vehicles
- Pads min. height 85 mm. only



- Hebebühne mit elektronischer Gleichlaufsteuerung ohne Grundrahmen für die einfachste Bedienung in der Arbeitszone.
- Die Verbindungskabel können sowohl über die Decke oder im Boden verlegt werden
- Die elektronische Gleichlaufsteuerung regelt den Gleichlauf der Hubschleitten und beschränkt den Ungleichlauf auf max. 24 mm
- Bedienungselemente liegen alle an Niederspannung (24 volt)
- Dreifach teleskopische lange und kurze Arme, um die problemlose asymmetrische Aufnahme von Lieferwagen und 'Off-Road'-Fahrzeugen zu gewährleisten
- Sehr niedrige Arme
- Aufnahmen mit einer Mindest-Unterschwenkhöhe von 85mm



- Elévateur avec synchronisation électronique sans base, facilitant le mouvement dans la zone de travail.
- Installation des câbles de connexion au plafond ou encastrés au sol
- La synchronisation électronique entre les chariots limite la dénivellation à un écart max de 24 mm
- Commandes à bas voltage
- Bras courts et bras longs en trois parties pour le levage asymétrique de fourgons et toutterrains
- Tampons de hauteur min. de 85 mm seulement



- Elevador con sincronización electrónica sin base: permite un fácil acceso al área de trabajo. Posibilidad de instalación de los cables en el techo o empotrados en el suelo
- La sincronización electrónica entre los carritos permite mantener un plazo máximo de desnivelación de 24 mm
- Controles a bajo voltaje
- Brazos cortos y largos a tres etapas para levantamiento asimétrico de furgonetas y vehículos de todoterrenos
- Brazos extra rebajados con perfil paralelo al suelo
- Tampones con altura maxima de sólo 85mm



H=+70mm



H=+100mm



H=+170mm



H=+250mm



Bracci predisposti per l'alloggiamento rapido di prolunghe

Arms suitable for quick drop-in extensions

Aufnahmen mit Schnellstecksystem erleichtern den Einsatz von Verlängerungen.

Bras prévus pour le montage rapide de rallonges

Brazos predispuestos para el alojamiento rápido de suplementos

V60-820



H=+198

V60-810



H=+143

V60-800



H=+113



Arresto bracci a inserimento automatico e sgancio automatico a terra

Automatic locking & unlocking of arms during on floor

Schwenkarmarretierung rastet automatisch ein (in der unteren Nullstellung) und aus (beim Heben aus der Nullstellung)

Arrêt des bras à insertion automatique et désinsertion automatique à terre

Parada de brazos de activación automática y desenganche automático de tierra



4 WD

Comando a uomo presente, 24V

Dead man controls, 24V

24V - Totman-Schaltung

Commande "homme mort", 24V

Mandos de hombre presente, 24V



OPTIONAL

CODE

DESCRIPTION

A-93007 Kit for vehicle 4WD - Kit 4 tamponi speciali per veicoli 4WD

A-93008 Adaptator for Mercedes / Iveco=105 - Adattatori per Mercedes / Iveco

A-93009 Adaptator for Mercedes / Iveco=135 - Adattatori per Mercedes / Iveco

A-93010 Adaptator for Mercedes / Iveco=190 - Adattatori per Mercedes / Iveco

A-93011 Expansion bolts set (14 pz) - Set tasselli di fissaggio (14pz)

A-93033 Kit extension pad + brackets - Kit prolunghe tampone + staffe